

# GGX15 Grease Guardian

## 230 VAC Specification/mm

**System features:**

Fully automatic grease removal system with PLC controller; Dry basket solids strainer for improved hygiene; No internal user tank maintenance required; Unversal flow direction, no flow reversal required to install; Pipework and electrical connections concealed from view.

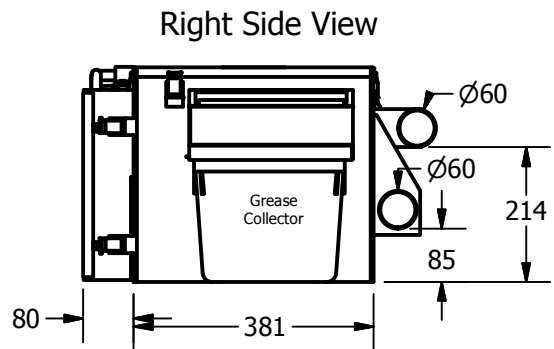
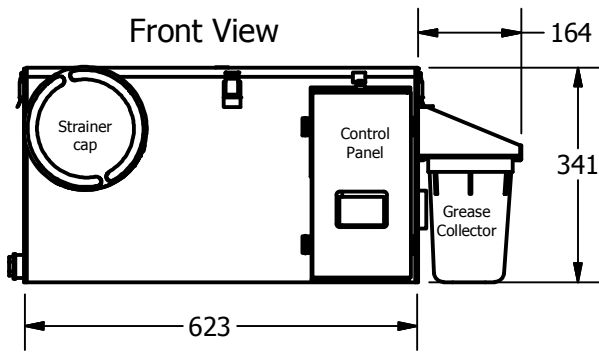

**Minimum Floor-space Recommendation**

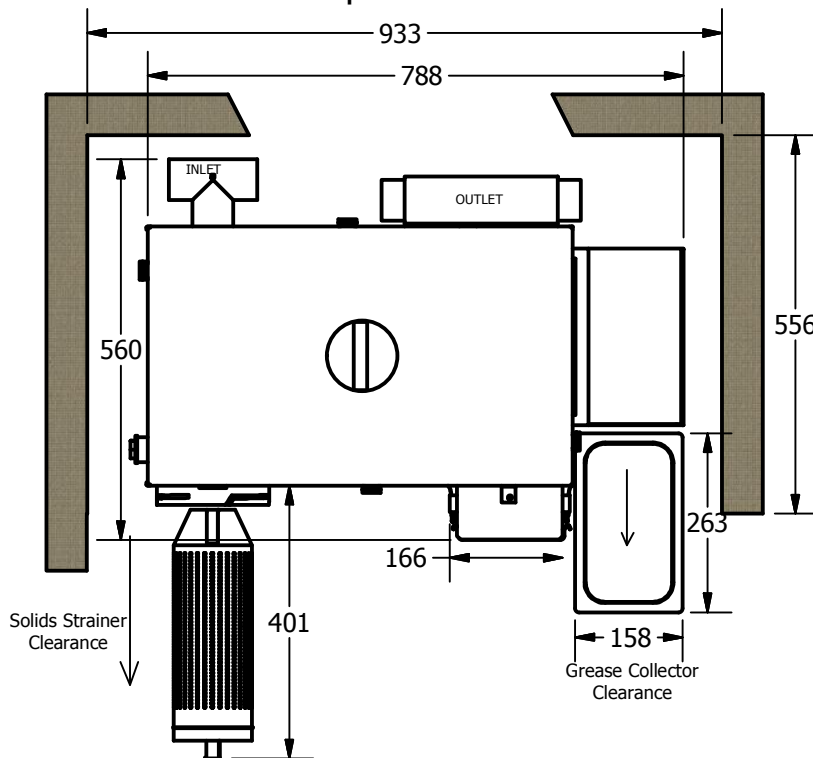

**KEY INSTALLATION NOTES:**

- Allow for the minimum clearances shown
- Allow adequate access to slide-in strainer & slide-in grease collector from front.
- Inlet port is both single/dual entry  
Outlet port is both single/dual entry.
- Keep outlet piping at 1:100 fall or more.
- User rubber adjustable pipe connectors as supplied.
- Only switch on after filling system with water to static level.
- Refer to ggx manual for full installation.

**TECHNICAL DATA**

Weight	30 kg ex works
Material	Exterior, 16 gauge stainless steel, bright finish
Interior	Stainless Steel and Acetal Plastic Components
Maximum Flow Rate	0.95 Litres per Second
Tank grease Retention Capacity	30 pounds minimally
Solid Strainer Capacity	6.6 pounds
Skimming Rate	11 pounds per hour
Progammng/Control	24 hour, 7 day, multi functional digital
Electrical Load	230VAC, 625Watts, 2.61 AMPS